

CO<sub>2</sub> concentration, temperature, humidity  
and other calculated humidity variables regulator

with two relay outputs

H5021

H5024

H6020

**Instruction Manual**

# Table of content

<b>1. GENERAL DESCRIPTION .....</b>	<b>4</b>
<b>2. REGULATOR MOUNTING AND CONNECTION.....</b>	<b>4</b>
<b>3. DIMENSIONS.....</b>	<b>5</b>
<b>4. DEVICE CONNECTION.....</b>	<b>6</b>
<b>5. DESCRIPTION OF DEVICE FUNCTION AND SETTING.....</b>	<b>7</b>
5.1. Device setting from the manufacturer .....	7
5.2. Relay outputs .....	7
5.3. Carbon dioxide concentration measurement .....	7
5.4. Actual regulator preset .....	8
5.4.1. Value assigned to output relay.....	8
5.4.2. When close output relay.....	8
5.5. Regulator setting change .....	9
5.5.1. Setting with PC and TSensor software.....	9
5.5.2. Setting with using regulator keys .....	10
5.5.3. Extended setting mode .....	10
5.6. Restore to „Factory default“ – measurement part .....	14
<b>6. ERROR STATES OF THE DEVICE .....</b>	<b>14</b>
<b>7. READINGS ON LCD DISPLAY.....</b>	<b>15</b>
<b>8. PREVENTIVE MAINTENANCE AND CALIBRATION .....</b>	<b>15</b>
<b>9. TECHNICAL SPECIFICATION.....</b>	<b>16</b>
9.1. Technical parameters.....	16
9.1.1. Common parameters .....	16
9.1.2. H5021 – CO <sub>2</sub> regulator.....	16
9.1.3. H5024 – CO <sub>2</sub> regulator.....	16
9.1.4. H6020 – temperature, relative humidity and CO <sub>2</sub> regulator .....	17
9.1.5. Relative humidity and temperature restriction .....	17
9.1.6. Value computed from measured relative humidity and temperature.....	18
9.2. Operating conditions .....	19
9.3. End of operation .....	20
9.4. Technical support and service .....	20
<b>10. APPENDIX A .....</b>	<b>21</b>
<b>11. APPENDIX B .....</b>	<b>21</b>

## General safety rules

The following summary is designed to prevent injury hazards or device damage. Operate the instrument in accordance with this manual to prevent electric trauma.

**Service should be performed by a qualified person only.**

**Connect and disconnect correctly.** Do not connect and disconnect lead-in cables if the device is under electric voltage.

**Do not use the instrument without the cover.**

**Do not use the instrument, if it does not work correctly.** If the instrument seems not to work correctly, have it checked by a qualified service person.

**Do not use the instrument in an explosive environment.**

**Read instruction manual before the first device connection, please.**

**Models marked HxxxxZ** are non-standard versions of the devices. Description is not included in this manual.

**Copyright:** COMET System, Ltd. It is prohibited to copy and edit this instruction manual and make any changes at all without explicit agreement of COMET System, Ltd. All rights reserved.

COMET System, Ltd makes constant development and improvement of all its products. That is why it reserves the right to make any technical changes on the device/product without previous notice.

Manufacturer is not responsible for damages caused by using the device in conflict with this manual. To damages caused by using the device in conflict with this manual cannot be provided free repairs during the warranty period.

Contact the manufacturer of this device:

COMET SYSTEM, s.r.o.  
Bezrucova 2901  
756 61 Roznov pod Radhostem  
Czech Republic  
[www.cometsystem.com](http://www.cometsystem.com)

# 1. General description

The regulators are designed for online measurement of temperature (°C or °F), relative humidity and carbon dioxide concentration of air without aggressive ingredients. Measured temperature and relative humidity are recomputed to following humidity expression: dew point temperature, absolute humidity, specific humidity, mixing ratio and specific enthalpy.

Type	Temperature	Humidity	CO <sub>2</sub>	Computed value
H5021	-	-	✓	-
H5024	-	-	✓	-
H6020	✓	✓	✓	✓

The device is equipped with two relay outputs for alarming or controlling of external devices. It is possible to assign any input value to each relay, to set comparing limit, delay, hysteresis and acoustic alarm.

Measured and computed values are optionally shown on dual line LCD display. If there are two values displayed at one LCD line, they are periodically switched between both readings with period of 4 seconds. Display can be switched OFF totally too. On the left LCD side there are placed three LEDs for CO<sub>2</sub> zone level indication.

# 2. Regulator mounting and connection

Regulators are designed for wall mounting. Device must be mounted on the plane surface to prevent its deformation. Mounting holes and connection terminals are accessible after demounting of four screws in the corners of the box and removing the lid. There is recommended to use screws with half round head with cross-recessed screw ST 3.9 (DIN 7981). Unpack external probe for measuring the concentration of CO<sub>2</sub> and connect to the device.

Lace the lead-in cable with outer diameter of 3 to 6.5 mm through the glands at the case wall and connect them according schematic below. Terminals are self-clamping and can be opened by a suitable screwdriver. For the opening, insert the screwdriver to smaller terminal hole and lever by him. Do not forget to tighten glands and case lid with inserted packing after cables connecting. Insert attached plug into unused cable glands too. Do not connect the regulator under voltage.

It is not recommended to use the H6020 regulator for long time under condensation conditions. It could be the cause of water steam condensation inside the sensor's cover into water phase. This liquid phase stays inside sensor's cover and can't escape from the cover easily. It can dramatically increase response time to relative humidity change. If water condensation occurs for longer time it can cause sensor damage. Similar effect can occur under water aerosol conditions.

Electrical system (wiring) may be done only by a worker with required qualification by rules in operation.

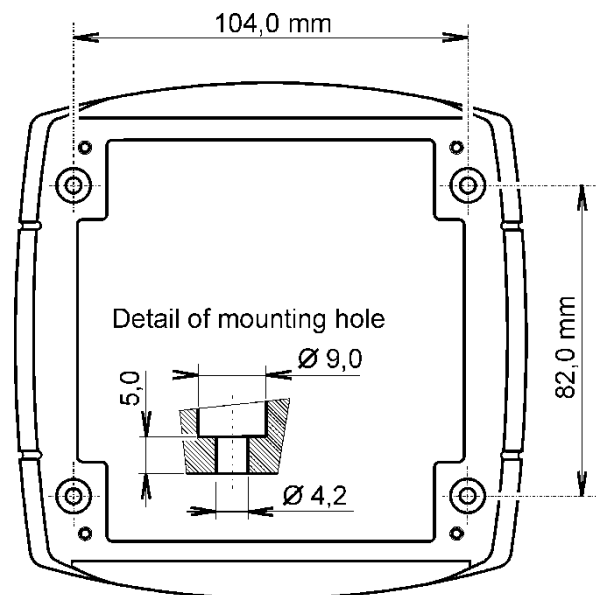

### 3. Dimensions

#### H5024

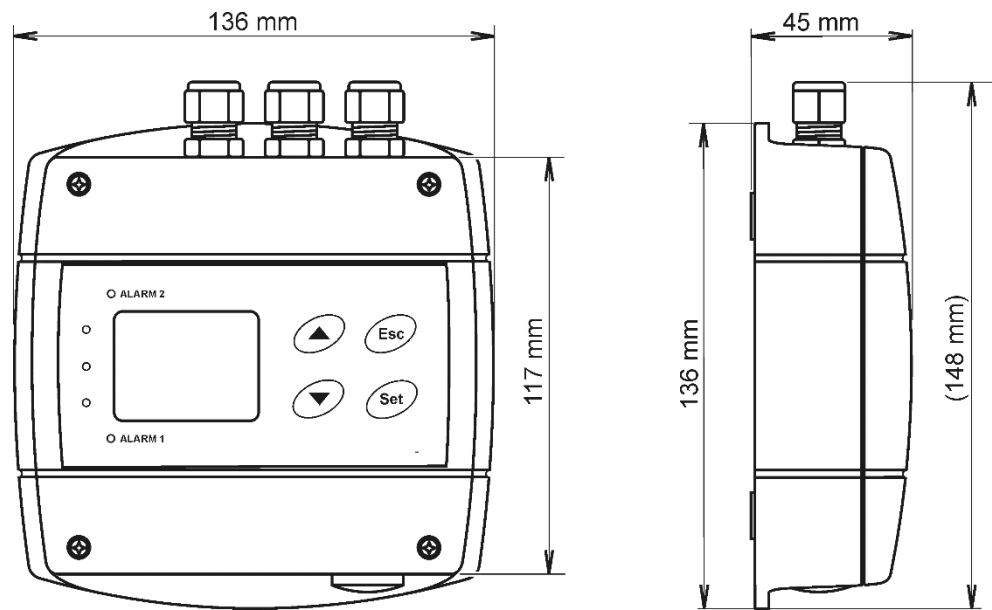

#### H6020

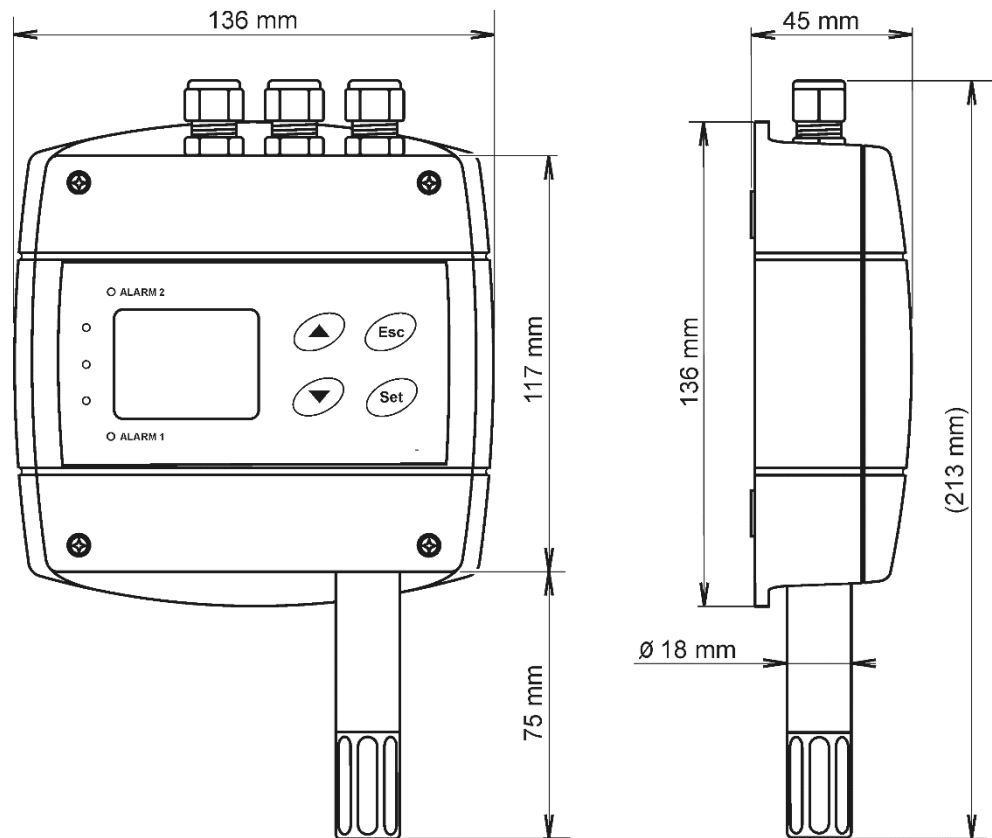

# H5021

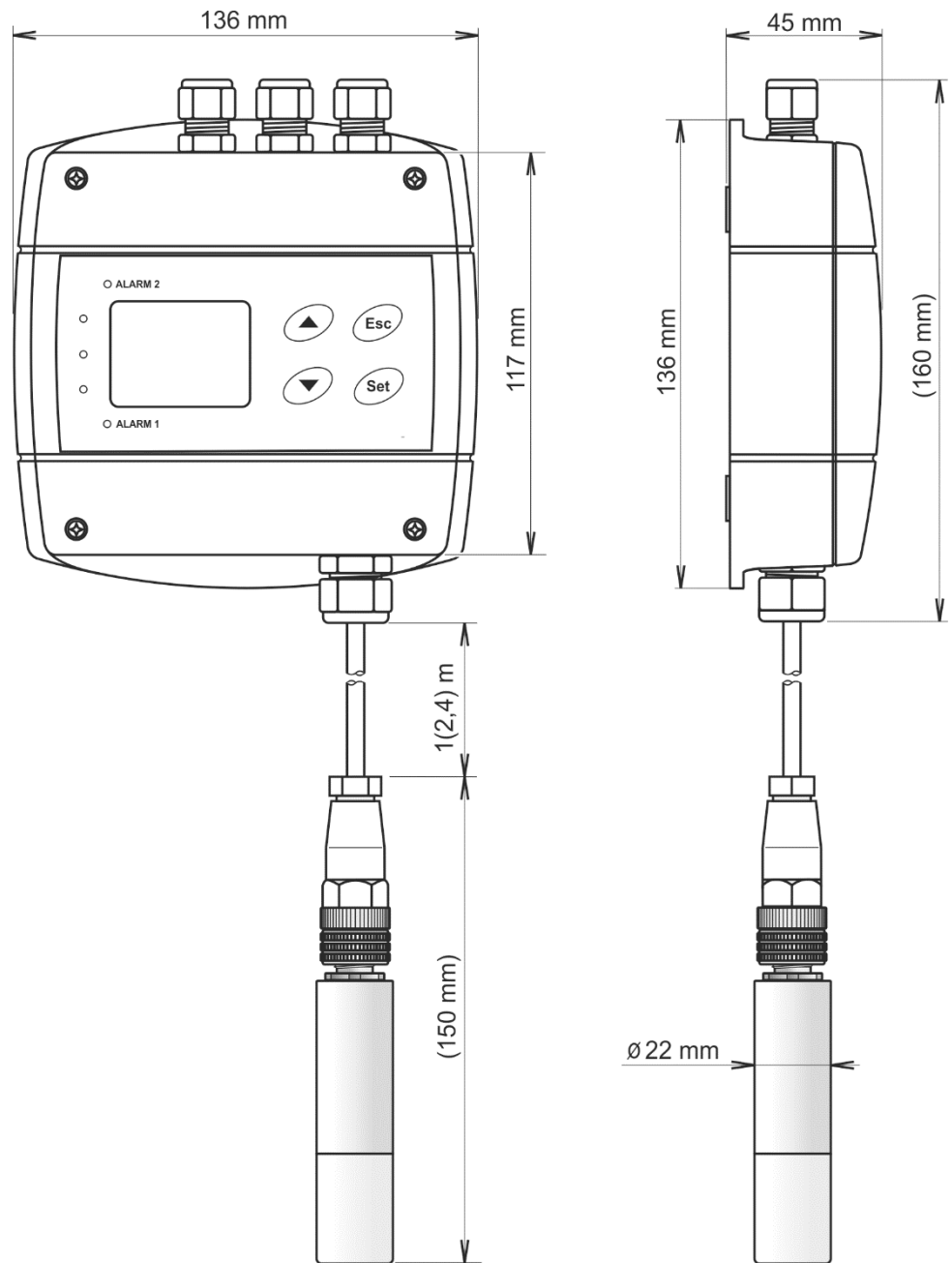

## 4. Device connection

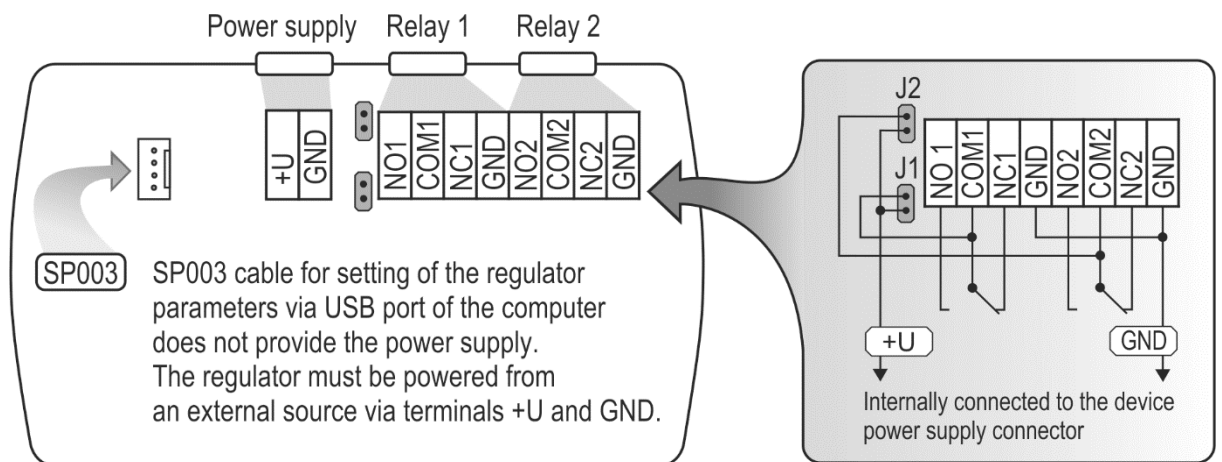

## 5. Description of device function and setting

### 5.1. Device setting from the manufacturer

Value assigned to Relay1 and Relay2:	<b>none</b>
Password for setting through keys:	<b>0000</b>
LCD display:	<b>on</b>
value shown at first LCD line:	<b>temperature / CO<sub>2</sub> - by device type</b>
value shown at second LCD line:	<b>relative humidity / dew point temp. - by device type</b>
temperature unit:	<b>°C</b>
computed value preset:	<b>dew point temperature</b>
relay response for error:	<b>stay unchanged at previous condition</b>
acoustic alarm:	<b>off</b>
LED indication:	<b>up to 1000 ppm lights green LED, between 1000 and 1200 ppm lights yellow LED and over 1200 ppm lights red LED</b>
altitude:	<b>300 m above sea level at the installation site</b>

### 5.2. Relay outputs

Regulator is equipped with two relay outputs. It is possible to assign any input or computed value to each relay, to set comparing alarm limit, if the relay may close if measured value is higher (HI) or lower (Lo) than preset limit, delay for while must be preset condition true before relay close its contact and hysteresis for return to open status. Each relay status is indicated with LED diode and shown on LCD with corresponding symbols „**ALARM 1**“ or „**ALARM 2**“.

Terminal block for connecting the relays is equipped with terminals GND, which are connected to the power supply of the device (see chapter “*Device connection*”). When you need to use relays to switching the voltage identical with the supply voltage of the device, you can use jumpers J1 and J2 for interconnection the power supply of the device directly with the common contacts of the relays. **This modification is used in devices with serial number higher than 16981000** (the wiring diagram of the relay contacts for devices with serial number lower than 16981000 is given in the “*Appendix B*”).

The devices are equipped with two relays that are not intended for direct switching power circuits or mains voltage. If necessary, use suitable type of external relay (an example of wiring is given in the “*Appendix A*”).

### 5.3. Carbon dioxide concentration measurement

A multiple point CO<sub>2</sub> and temperature adjustment procedure leads to excellent CO<sub>2</sub> measurement accuracy over the entire temperature working range; this is a must for process control and outdoor applications. The dual wavelength NDIR CO<sub>2</sub> sensing procedure compensates automatically for ageing effects. The CO<sub>2</sub> module is highly resistant to pollution and offers maintenance free operation and outstanding long term stability. Measured values can be read in „SLOW mode“ (filtered, averaged) or in „FAST mode“ (current values without averaging). SLOW mode has advantages in applications like climate control because of filtering short time peaks. As an example exhaled air from an employee passing the sensor could affect the climate control negatively with a short response time because the control would trigger a change of the ventilation based on this one-time measurement. On the contrary in „FAST mode“ no software filter is used for calculating the output

value. This fact adds a noise of typ.  $\pm 30$  ppm which has to be considered in terms of accuracy. From the principle of measurement, the measured value of CO<sub>2</sub> concentration depends on the value of air pressure - altitude at the installation site. For this reason, it is suitable for accurate measurement to set the altitude of the installation site by TSensor software.

After power up there is internal check in progress and takes about 20 s. During this time LCD display shows (---) instead of CO<sub>2</sub> concentration value.

Parameter setting description is into chapter “*Extended setting mode*” at page 10.

## 5.4. Actual regulator preset

It is possible to display actual regulator preset on its LCD display by pressing of „▲“ key. LCD shows information about Relay1 and then Relay2 setting step by step. Information about Relay1 are indicated with symbol „ALARM 1“, for Relay2 with symbol „ALARM 2“ (at right top corner of LCD). It is possible to edit parameters after pressing „SET“ key and entering of correct password „PASS“ – see chapter „*Change of “Password for setting through keys” (PASS)*“ at page 10. Following examples are for Relay1 setting, similarly are displayed values for Relay2. Pressing of „ESC“ key ends this mode and switch to actual value displaying, the same occur if more than 20 s is not pressed any key.

### 5.4.1. Value assigned to output relay

*None, relay is still off*



*Temperature at °C*



*Relative humidity*



*Computed value – dew point temperature*



*CO<sub>2</sub> concentration*

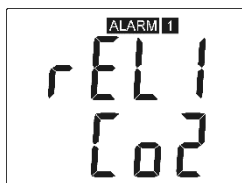

### 5.4.2. When close output relay

**High limit „HI“** – the relay closes when measured value exceeds preset „high limit” for longer time than preset „delay time“. Relay goes open when measured value decrease under „high limit“ value minus the „hysteresis” value. See example.

*High limit „HI“*

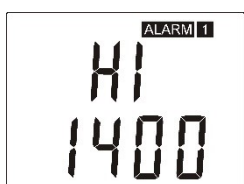

*Delay [s]*

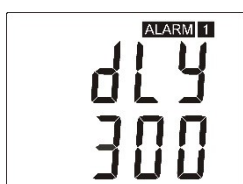

*Hysteresis*





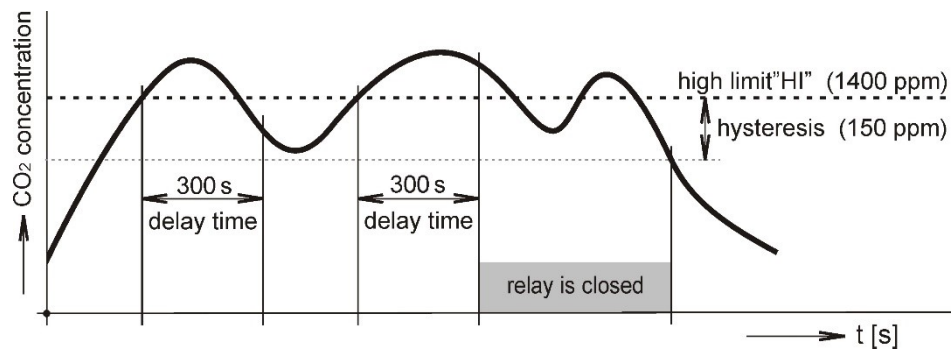

**Low limit „Lo“** – the relay closes when measured value falls below preset „low limit“ for longer time than preset „delay time“. Relay goes open when measured value exceeds „low limit“ value plus the „hysteresis“ value. See example.

Low limit „Lo“

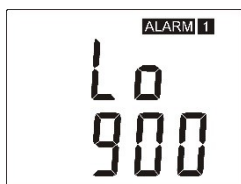

Delay [s]

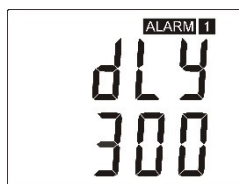

Hysteresis

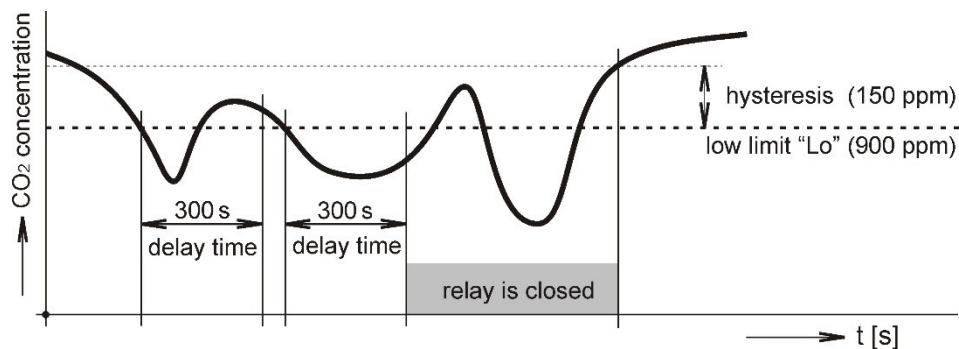
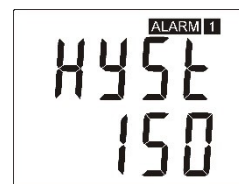

## 5.5. Regulator setting change

### 5.5.1. Setting with PC and TSensor software

Device adjustment is performed by means of optional **SP003** communication cable connected to USB port of PC. It is necessary to have installed program **TSensor** on the PC (the program is available free to download at web page [www.cometsystem.com](http://www.cometsystem.com)). Run the program and follow the program instructions. Regulator includes hardware write protection of internal setting, new setting is possible to write only while:

- during write period press „SET“ key – do requested setting in TSensor software, press „SET“ key on regulator and keep it down, then click on the button „Save Changes“ into TSensor software and after end of write release „SET“ key, or
- jumper placed nearby keys is closed (jumper is accessible after demounting of four screws in the corners of the box and removing the lid, don't confuse with jumper nearby Ethernet connector!). This jumper is suitable e.g. until device adjustment is in process and regulator is placed into calibration box and keys are not accessible. Don't forget to remove (open) jumper after procedure finish (restore write protection)

TSensor software supports to make the adjustment of the regulator too. This procedure is described at file „*Calibration manual.pdf*“ which is installed commonly with the software.

### 5.5.2. Setting with using regulator keys

If „Actual regulator preset” is displayed, it is possible to enter into edit mode and edit displayed value by pressing „SET” key. You can edit selected value if right password is entered. During value editing there is range check executed and edited value is still compared with limits for corresponding value (range). If inserted value is higher or lower, then edited number is automatically changed to its maximum / minimum value – for possible range see chapter „Technical parameters“ at page 16. Value can be changed with using „▲” and „▼” keys. Edited value is switched in “round” -9, -8, -7, ...-2, -1, 0, 1, 2, ...8, 9. To edit next number digit press „SET” key, for moving back to previous digit press „ESC” key. Edited value is stored by next „SET” key pressing. It is possible to cancel editing by pressing „ESC” key if necessary. If valid password is once inserted right, then there is possible to edit next items without asking for password insertion again, till “Actual regulator preset” is left (till actual measured values are shown). With new entering into edit mode it is necessary to enter Password again. Default password setting is preset from manufacturer to 0000, password change is possible into „Extended setting”. During edit mode regulator still works and changes are valid immediately after its storing – it is NOT necessary to restart regulator.

### 5.5.3. Extended setting mode

During regulator operation it is possible to change only parameters described in chapter “*Actual regulator preset*” at page 8. Rest of regulator parameters are available through “Extended setting mode”. **In this mode regulator does NOT communicate, does NOT do any measurements and does NOT service output relays. To leave this mode press „ESC” key and open jumper nearby keys.** To enter into Extended setting mode do following steps:

1. disconnect power supply
2. demount four screws in the corners of the box and remove the lid
3. closed jumper placed nearby keys (don't confuse with jumper nearby Ethernet connector)
4. press „▲” and „▼” keys together and keep them down
5. connect power supply to regulator – you should see message „SEL” on the top line of LCD and on the bottom line you should see number of Firmware version (e.g. 0400)
6. release „▲” and „▼” keys – you are into “Extended setting mode” now

Use „▲” and „▼” keys to inspect each items. If you want to change some shown item then press „SET” key, item starts blink. Now you can edit setting with using „▲” and „▼” keys. To store preset value press „SET” key. Press „ESC” key to leave editing (changing) without save – last stored value is kept.

### Acoustic alarm assign to Relay1 (Relay2)

*acoustic indication of Relay1 is OFF*



*close of Relay1 contact starts acoustic indication*



*acoustic indication of Relay2 is OFF*



*close of Relay2 contact starts acoustic indication*



## Acoustic alarm deactivation

activated acoustic alarm is possible to deactivate by pressing „ESC“ key

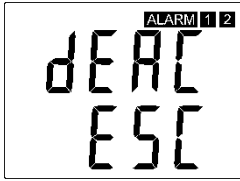

acoustic alarm is still activated for all time and it is impossible to deactivate it



## Relay response for error

Regulator continuously checks its state during operation. In case error of assigned value measurement is found then output relay:

stays unchanged (in previous status)



Relay1 switch OFF



Relay1 switch On



stays unchanged (in previous status)



Relay2 switch OFF



Relay2 switch On



password setting

## Change of “Password for setting through keys” (PASS)

This item shows actual password setting. It is possible to change it after „SET“ key pressing. It is number from range -19999 to +19999.

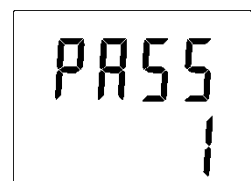

## Temperature unit choice

It is possible to measure temperature at °C or °F. There is shown preset unit. It is possible to change it after „SET“ key pressing.

preset to °C

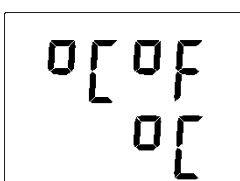

preset to °F

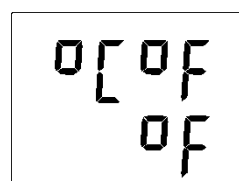

## CO<sub>2</sub> measurement mode selection

This item provides to choice if measured value is displayed and read in “SLOW” or “FAST” mode. “FAST” mode provides last measured value without averaging; this means that no software filter is used for calculating the output value. “SLOW” mode provides value averaged from last 11 measured values.

*averaged value „SLOW“ mode*

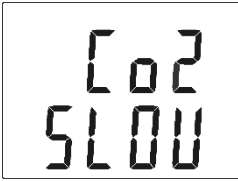

*current value without averaging „FAST“ mode*

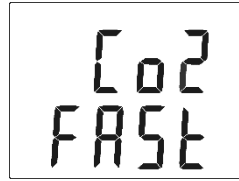

## CO<sub>2</sub> zone level indication setup

Whole measuring range can be divided into three areas. Each active area there is indicated by green, yellow or red LED depends on actual measured value. It is done by two boundary limits setting. „YELL“ limit sets boundary between green and yellow indication. It means that if actual measured value is lower than „YELL“ limit, there is green LED active. If actual measured value is higher than „YELL“ limit, then there is yellow LED active. Yellow LED lights until actual measured value exceeds „RED“ limit. If actual value is higher than „RED“ limit, red LED is active. If you don't want to use this indication then set “YELL” limit to 0.

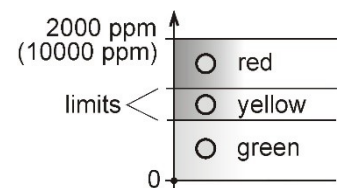

*„YELLOW“ limit setting*

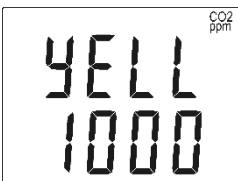

*„RED“ limit setting*

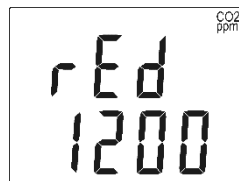

## Show temperature at LCD display

This item provides to choice if actual measured temperature may be displayed at LCD display or not. It is possible to change it after „SET“ key pressing.

*show value on LCD*

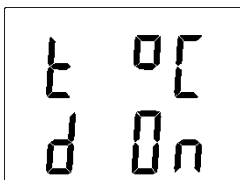

*don't show value on LCD*



## Show relative humidity at LCD display

This item provides to choice if actual measured relative humidity may be displayed at LCD display or not. It is possible to change it after „SET“ key pressing.

*show value on LCD*

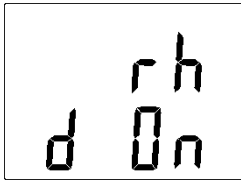

*don't show value on LCD*

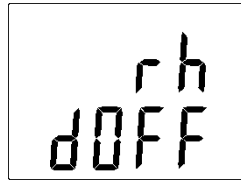

### Show computed value at LCD display

This item provides to choice if actual computed value may be displayed at LCD display or not. There is shown the name of computed value on the top LCD line – see “Computed value selection“ below. It is possible to change it after „SET“ key pressing.

*show value on LCD*

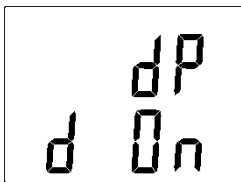

*don't show value on LCD*

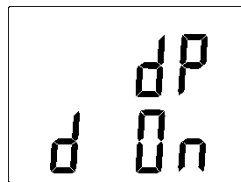

### Show CO<sub>2</sub> concentration at LCD display

This item provides to choice if CO<sub>2</sub> value may be displayed at LCD display or not. It is possible to change it after „SET“ key pressing.

*show value on LCD*

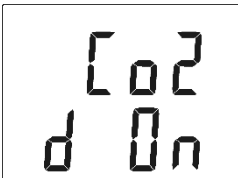

*don't show value on LCD*



### Computed value selection

It shows the actually selected computed value name. It is possible to change it after „SET“ key pressing. There is possible choice one of the following computed values:

*dew point temperature*



*absolute humidity*



*mixing ratio*



*specific humidity*



*specific enthalpy*

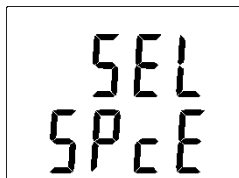

## 5.6. Restore to „Factory default“ – measurement part

This item provides regulator restoring to factory setting. Press „SET“ key, select „YES“ and confirm it by pressing of „SET“ key. It reset regulator parameters to following values:

Value assigned to relay 1 and relay 2:	<b>none</b>
Password for setting through keys (PASS):	<b>0000</b>
display:	<b>on</b>
temperature unit:	<b>°C</b>
correction for altitude:	<b>0 hPa (absolute pressure)</b>
computed value preset:	<b>dew point temperature</b>
relay response for error:	<b>stay unchanged at previous condition</b>
acoustic alarm:	<b>off</b>

*restore to factory default*

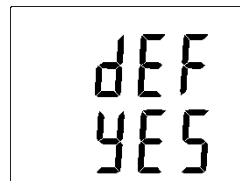
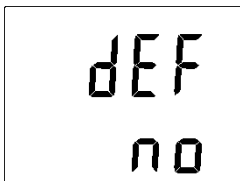

## 6. Error States of the device

Device continuously checks its state during operation. In case error is found LCD displays corresponding error code:

**Error 0** - first line of LCD displays „Err0“. Check sum error of stored setting inside device’s memory. This error appears if incorrect writing procedure to device’s memory occurred or if damage of calibration data appeared. At this state device does not measure and calculate values. It is a serious error, contact distributor of the device to fix.

**Error 1** - measured or calculated value (except concentration of CO<sub>2</sub>) is over upper limit of allowed full scale range. There is a reading „Err1“ on LCD display. Value read from the device is +999.9. This state appears in case of:

- Measured temperature is higher than approximately 600°C (i.e. high non-measurable resistance of temperature sensor, probably opened circuit).
- Relative humidity is higher than 100%, i.e. damaged humidity sensor, or humidity calculation of humidity is not possible (due to error during temperature measurement).
- Computed value – calculation of the value is not possible (error during measurement of temperature or relative humidity or value is over range).

The value of CO<sub>2</sub> concentration 9999 ppm is correct value!

**Error 2** - there is a reading „Err2“ on LCD display. Measured or calculated value is below lower limit of allowed full scale range or CO<sub>2</sub> concentration measurement error occurred. Value read from the device is -999.9. This state appears in case of:

- Measured temperature is lower than approximately -210°C (i.e. low resistance of temperature sensor, probably short circuit).
- Relative humidity is lower than 0%, i.e. damaged sensor for measurement of relative humidity, or calculation of humidity is not possible (due to error during temperature measurement).
- Computed value – calculation of computed value is not possible (error during measurement of temperature or relative humidity).

**Error 3** - there is a reading „Err3“ on LCD display upper line. Error of internal A/D converter appeared (converter does not respond, probably damage of A/D converter). At this state device does not measure temperature and relative humidity. This error does not affect CO<sub>2</sub> concentration measurement. It is a serious error, contact distributor of the device.

**Error 4** - there is a reading „Err4“ on LCD display. It is internal device error during CO<sub>2</sub> concentration sensor initialization. Under this condition device does not measure concentration of CO<sub>2</sub>. Value read from device is -9999 (concentration of CO<sub>2</sub>). CO<sub>2</sub> sensor is probably damaged. It is a serious error, contact distributor of the device. For devices with an external probe CO2G-10 the “Err4” indicates that the probe is not connected.

**Error 5,6** - there is problem with assigned value to output relay, there is some wrong setting (mismatch). This error appears if incorrect writing procedure to device’s memory occurred.

**Error 9** - inserted password is not valid, there is shown for short time message “Err9” on LCD display.

## 7. Readings on LCD display

°C, °F - reading next to this symbol is measured temperature or error state of value

%RH - reading next to this symbol is measured relative humidity or error state of value

CO<sub>2</sub> ppm - reading next to this symbol is measured concentration of CO<sub>2</sub> or error state of value.

°C / °F DP - reading next to this symbol is calculated dew point temperature or error state of value

g/m<sup>3</sup> - reading next to this symbol is calculated absolute humidity or error state of value

g/kg - reading next to this symbol is calculated specific humidity or mixing ratio (depends on device setting) or error state of value

3 - this symbol is on if jumper is closed

If specific enthalpy is selected, there is shown only value (number) without corresponding unit

## 8. Preventive maintenance and calibration

Pay heed to recommended calibration interval. Do not subject the device to mechanical stress.

## 9. Technical specification

### 9.1. Technical parameters

#### 9.1.1. Common parameters

**Power voltage:** 9 to 30 V DC

**Power consumption:** 1W during normal operation  
4W for 50ms with 15 s period

**Measuring interval:** temperature, relative humidity . . . . . 0,5s  
CO<sub>2</sub> concentration . . . . . 15s

**Display switching interval:** 4 s (when more than two values are displayed)

**Relay outputs:** Amount: 2  
Maximal voltage: 50 V  
Maximal current: 2A  
Maximal power: 60 VA  
Relays contact is not designed for direct control of line voltage!  
(relay contact parameters: max 220Vdc, 125Vac, 2A, 60 W, 62.5 VA)

**EMC:** EN 61326-1, EN 55011

#### 9.1.2. H5021 – CO<sub>2</sub> regulator

##### Concentration of CO<sub>2</sub>:

Accuracy:  $\pm (100 \text{ ppm} + 5 \% \text{ of measuring value})$  at 25°C (77°F) and 1013 hPa

Range: 0 to 10000 ppm

Temp. dependence:  $\pm (1 + \text{measured value [ppm]}/1000) \text{ [ppm}/^\circ\text{C}]$  in the range -20 to 45 °C  
(-4 to 113°F)

Resolution: 1 ppm

**Response time:**  $t_{63} < 140 \text{ s}$  in „SLOW“ measurement mode

$t_{63} < 75 \text{ s}$  in „FAST“ measurement mode

#### 9.1.3. H5024 – CO<sub>2</sub> regulator

##### Concentration of CO<sub>2</sub>:

Accuracy:  $\pm (50 \text{ ppm} + 2 \% \text{ of measuring value})$  at 25°C (77°F) and 1013 hPa

Range: 0 to 2000 ppm

Temperature dependence: typ. 2 ppm CO<sub>2</sub> / °C in the range 0 to 50 °C (32 to 122°F)

Long term stability: typ. 20 ppm / year

Resolution: 1 ppm

**Response time:**  $t_{90} < 195 \text{ s}$  in „SLOW“ measurement mode

$t_{90} < 75 \text{ s}$  in „FAST“ measurement mode



### 9.1.4. H6020 – temperature, relative humidity and CO<sub>2</sub> regulator

#### Temperature:

Accuracy:  $\pm 0,4\text{ }^{\circ}\text{C}$  ( $\pm 0,7\text{ }^{\circ}\text{F}$ )  
Range:  $-30\text{ to }+60\text{ }^{\circ}\text{C}$  ( $-22\text{ to }140\text{ }^{\circ}\text{F}$ )  
Resolution:  $0,1\text{ }^{\circ}\text{C}$  ( $0,2\text{ }^{\circ}\text{F}$ )

#### Relative humidity:

Accuracy:  $\pm 2,5\text{ \%RH}$  from 5 to 95 %RH at  $23\text{ }^{\circ}\text{C}$  ( $73,4\text{ }^{\circ}\text{F}$ )  
Range: 0 to 100 %RH  
Resolution:  $0,1\text{ \%RH}$

#### Concentration of CO<sub>2</sub>:

Accuracy:  $\pm (50\text{ ppm} + 2\text{ \% of measuring value})$  at  $25^{\circ}\text{C}$  ( $77^{\circ}\text{F}$ ) and 1013 hPa  
Range: 0 to 2000 ppm  
Temperature dependence: typ.  $2\text{ ppm CO}_2 / ^{\circ}\text{C}$  in the range 0 to  $50\text{ }^{\circ}\text{C}$  ( $32\text{ to }122^{\circ}\text{F}$ )  
Long term stability: typ.  $20\text{ ppm / year}$   
Resolution: 1 ppm

**Measuring temperature and humidity range is limited** in accordance with the graph below.

**Response time measurement of temperature and relative humidity** with stainless steel mesh sensor cover (F5200B) and bronze sensor cover (F0000 - selectable option), air flow approximately 1 m/s:

temperature:  $t_{90} < 6\text{ min}$  (temperature step  $20\text{ }^{\circ}\text{C}$  ( $36\text{ }^{\circ}\text{F}$ ))  
relative humidity:  $t_{90} < 30\text{ s}$  (humidity step 65 %RH, constant temperature)

#### Response time measurement of CO<sub>2</sub> concentration:

$t_{90} < 195\text{ s}$  in „SLOW“ measurement mode  
 $t_{90} < 75\text{ s}$  in „FAST“ measurement mode

### 9.1.5. Relative humidity and temperature restriction

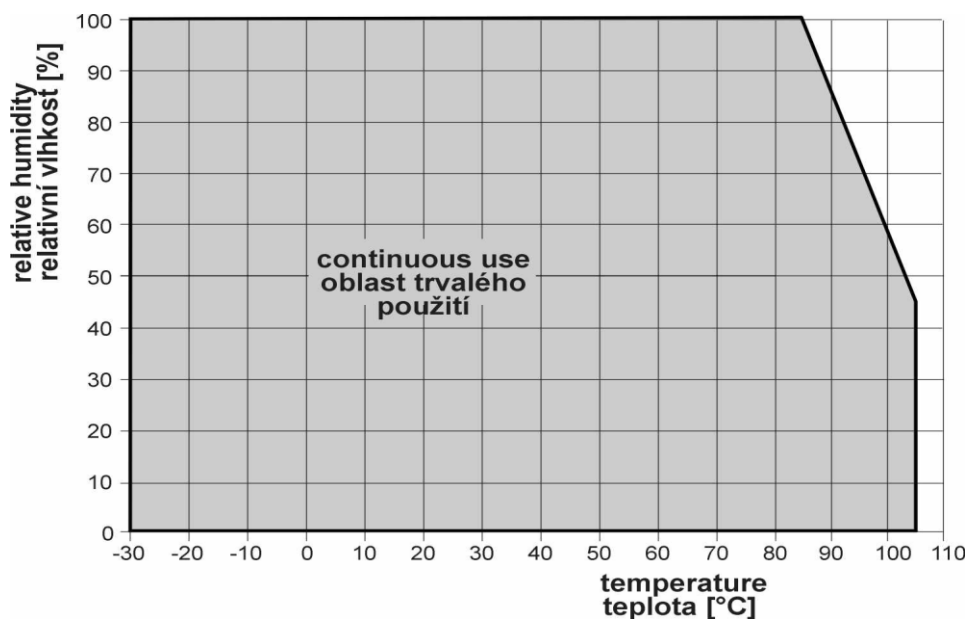

### 9.1.6. Value computed from measured relative humidity and temperature

#### Dew point temperature

Range: -60 to +80 °C (-76 to 176 °F)

Accuracy:  $\pm 1,5^{\circ}\text{C}$  ( $\pm 2,7^{\circ}\text{F}$ ) at ambient temperature  $T < 25^{\circ}\text{C}$  ( $77^{\circ}\text{F}$ ) and relative humidity  $\text{RH} > 30\%$ , for more details see graphs below

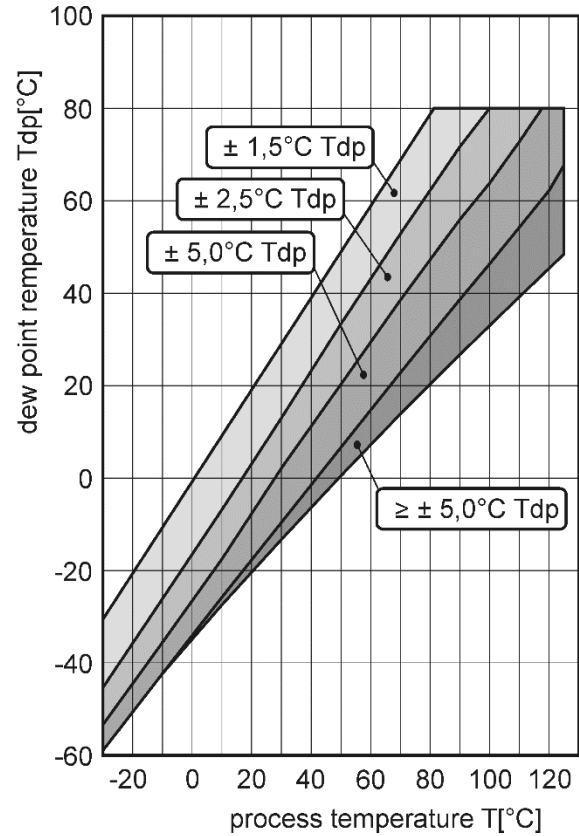
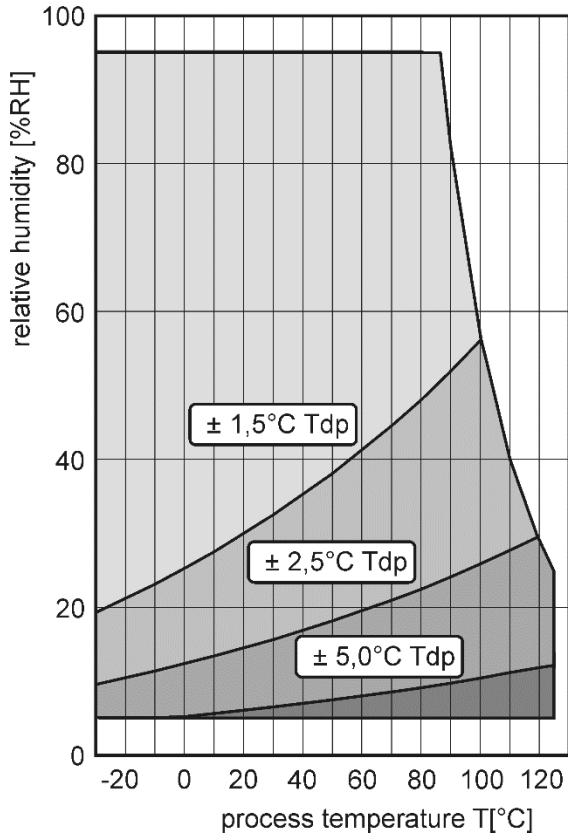

#### Absolute humidity

Range: 0 to 400 g/m<sup>3</sup>

Accuracy:  $\pm 1,5 \text{ g/m}^3$  at ambient temperature  $T < 25^{\circ}\text{C}$  ( $104^{\circ}\text{F}$ ), for more details see graph below

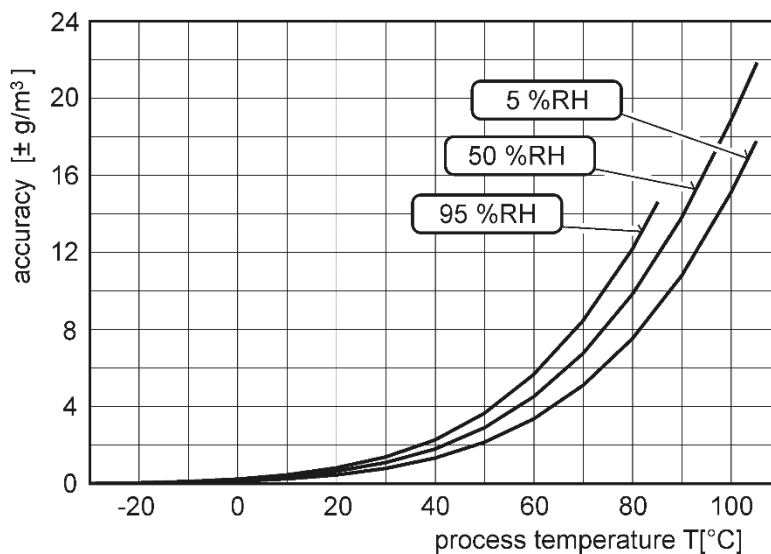

**Specific humidity<sup>1</sup>**

Accuracy: ±2g/kg at ambient temperature T &lt; 35°C (95 °F)

Range: 0 to 550 g/kg

**Mixing ratio<sup>1</sup>**

Accuracy: ±2g/kg at ambient temperature T &lt; 35°C (95 °F)

Range: 0 to 995 g/kg

**Specific enthalpy<sup>1</sup>**

Accuracy: ± 3kJ/kg at ambient temperature T &lt; 25°C (77 °F)

Range: 0 to 995 kJ/kg<sup>2</sup>

The values computed from ambient temperature and relative humidity including their accuracy you can exactly determine by the program **Conversions**. It is free to download at [www.cometsystem.com](http://www.cometsystem.com).

## 9.2. Operating conditions

**Operating temperature range:****electronics H5021:** -30 to +80 °C (-22 to 176 °F)**electronics H5024, H6020:** -30 to +60 °C (-22 to 140 °F)**measuring end of stem H6020:** -30 to +80 °C (-22 to +176 °F)**CO<sub>2</sub> probe H5021:** -25 to +60 °C (-13 to +140 °F) (fixed installation)

-5 to +60 °C (23 to +140 °F) (moving use)

*It is recommended to switch off the LCD display at ambient temperatures above 70°C (158 °F) around electronics.*

**Operating humidity range:****H5021:** 0 to 100 % RH (no condensation)**H5024, H6020:** 5 to 95 % RH (no condensation)**CO<sub>2</sub> probe H5021:** 0 to 95 % RH (no condensation)**Operating pressure range:** 850 to 1100 hPa**Protection:****H5021** IP65 (electronics), IP65 (CO<sub>2</sub> probe)**H5024** IP65 (electronics)**H6020** IP30 (electronics), IP40 (measuring end of stem)**Other environmental conditions (external influences) according to HD 60364-5-51:** normal**Recommended calibration interval:****H5021** 5 years (CO<sub>2</sub>)**H5024** 5 years (CO<sub>2</sub>)**H6020** 5 years (CO<sub>2</sub>), 1 year (relative humidity), 2 years (temperature)**Working position:****H5021** negligible**H5024** with cable glands upwards**H6020** with sensor cover downwards

<sup>1</sup> This value depends on the atmospheric pressure. For computing is used constant value stored in device memory. Default value preset by manufacturer is 1013hPa and can be changed by user's software.

<sup>2</sup> This maximum is reached under conditions about 70°C/100%RH or 80°C/70%RH

**Not allowed manipulations:** It is not allowed to operate the device under conditions other than specified in technical parameters. Devices are not designed for locations with chemically aggressive environment. Temperature and humidity sensors must not be exposed to direct contact with water or other liquids. It is not allowed to remove the sensor cover to avoid any mechanical damage of the sensors.

**Storage conditions:**

**temperature:** -40 to +60 °C (-40 to 140 °F)  
CO<sub>2</sub> external probe -25 to +60 °C (-13 to 140 °F)

**relative humidity:** 5 to 95 % RH (no condensation)  
CO<sub>2</sub> external probe 0 to 95 % RH (no condensation)

**atmospheric pressure:** 700 až 1100 hPa

**Dimensions:** see dimensional drawings

**Weight:** approximately:

<b>H5021/1m probe</b>	420 g
<b>H5021/2m probe</b>	450 g
<b>H5021/4m probe</b>	510 g
<b>H5024</b>	330 g
<b>H6020</b>	350 g

**Material of the case:** ASA/ABS

### 9.3. End of operation

Disconnect the device and dispose it according to current legislation for dealing with electronic equipment.

### 9.4. Technical support and service

The adjustment procedure is described at file „*Calibration manual.pdf*“ which is installed commonly with the TSensor software.

Technical support and service is provided by distributor. For contact see warranty certificate. You can use discussion forum at web address: <http://www.forum.cometsystem.cz/>.

# 10. Appendix A

## Connection of external power relay

### Coil data chart of external power relay:

nominal voltage : max. 50V  
 nominal power: max. 60VA  
 current: max. 2A

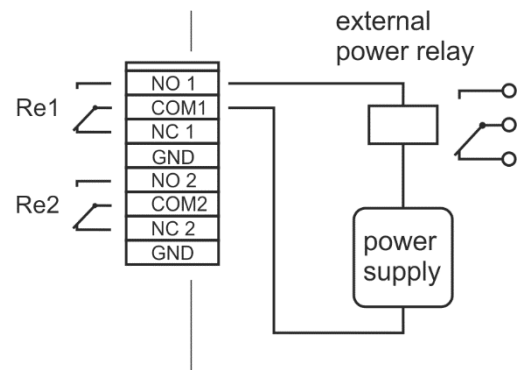

# 11. Appendix B

Wiring diagram of relay contacts for devices with serial number lower than **16981000**.

