

PRODUCT DESCRIPTION

Programmable regulators with relay outputs are designed to measure temperature and relative humidity of air, to measure concentration of CO₂ in air, to signal alarms and control of external devices. Regulators can be used in a chemical non-aggressive environment.

The CO₂ concentration is measured using the dual wavelength NDIR sensor with the multipoint calibration. This principle compensates aging of the sensing elements and offers maintenance free operation and outstanding long term stability.

The function of two output relays can be set from regulator keyboard (or from computer) and using the jumpers (see „Electrical wiring“). Each relay can be assigned to one of measured or computed value (dew point temperature, absolute humidity, specific humidity mixing ratio and specific enthalpy). Setting of delay, hysteresis, audible alarm is enabled for each relay. Measured and calculated values are displayed on a two-line display. The visual indication of the CO₂ concentration is provided by three LEDs to the left side of the display. Using *TSensor* software (see www.cometsystem.com) can be all regulator parameters set. To connect to PC is used USB adapter SP003 (optional accessories).

type *	measured values	construction	mounting
H5021	CO ₂	probe on cable	wall
H5024	CO ₂	ambient air	wall
H6020	T + RH + CO ₂ + CV	ambient air	wall

* models marked HxxxxZ are custom - specified devices

T...temperature, RH...relative humidity, CO₂...concentration of CO₂ in air, CV...computed values

INSTALLATION AND OPERATION

The mounting holes and connection terminals are accessible after unscrewing the four screws in the corners of regulator and removing the lid. Devices have to be mounted on a flat surface to prevent deformation. Pass cables (external diameter 3 to 6.5 mm) through released glands and connect wires according to diagram. Wire cross-section choose from 0.14 to 1.5mm². Tighten glands and screw the lid. Insert attached plugs into unused cable glands too. Unpack the external CO₂ probe (H5021) and connect it to the device. Pay attention to mounting the device and probe, because incorrect choice of working position or place of measuring could adversely affect accuracy and long-term stability of measured values.

Actual parameters settings of each relay can be displayed by pressing of „▲“ key. To change any parameter, press the „Set“ key, enter password (default 0000) and set required value. Then click on „Set“ and pressing „Esc“ key exit setup mode. To change the password and to set all other parameters (alarm settings, limits of CO₂ indication, used units, computed value selection etc.) is used **Extended setting mode** (see manuals for devices at www.cometsystem.com).

After switching the device starts internal test. During this time (about 20 s) LCD display shows ---- instead of CO₂ concentration value.

Devices don't require special maintenance. We recommend you periodical calibration for validation of measurement accuracy.

ERROR STATES

Device continuously checks its state during operation and if an error appears, it is displayed relevant code:

Err 1 – measured value (except the concentration CO₂) or calculated value is over the upper limit

Err 2 – measured or calculated value is below the lower limit or concentration CO₂ measurement error occurred

Err 5, Err 6 – there is problem with assigned value to output relay

Err 9 – inserted password is not valid

Err 0, Err 3, Err 4 – it is a serious error, please contact distributor of the device (for device with an external probe CO2G-10 the **Err 4** indicates that the probe is not connected)

SAFETY INSTRUCTIONS



- Don't use and don't store the devices without the cover of the temperature and humidity sensors.
- Temperature and humidity sensors have not to be exposed to direct contact with water and other liquids.
- It is not recommended to use the humidity regulators for long time under condensation conditions.
- Take care when unscrewing the filter cap as the sensor element could be damaged.
- Don't connect or disconnect devices while power supply voltage is on.
- Installation, electrical connection and commissioning should be performed by qualified personnel only.
- Devices contain electronic components, it needs to liquidate them according to currently valid conditions.
- **To complement the information in this data sheet** read the manuals and other documentations that are available in the Download section for a particular device at www.cometsystem.com.

Technical specifications

Device type	H5021	H5024	H6020
Supply voltage / power consumption of the device during normal operation / max. power consumption of the device (for 50 ms with 15 s period)	9 - 30Vdc / 1W / 4W	9 to 30Vdc / 1W / 4W	9 to 30Vdc / 1W / 4W
Relay outputs - max. switching voltage / max. switching current / max switching power	50V / 2A / 60VA	50V / 2A / 60VA	50V / 2A / 60VA
Temperature measuring range	—	—	-30 to +80 °C
Accuracy of temperature measurement	—	—	± 0.4 °C
Relative humidity (RH) measuring range	—	—	0 to 100 %RH
Accuracy of humidity measurement from 5 to 95 %RH at 23 °C	—	—	± 2.5 %RH
CO ₂ concentration measuring range *	0 to 10 000 ppm	0 to 2000 ppm	0 to 2000 ppm
Accuracy of CO ₂ concentration measurement at 25 °C and 1013 hPa	± (100ppm+5% of measured value)	± (50ppm+2% of measuring value)	± (50ppm+2% of measuring value)
Temperature dependence of CO ₂ concentration measurement at -20 to 45 °C	± (1+CO ₂ [ppm]/1000) ppm/°C	typ. 2 ppm CO ₂ /°C	typ. 2 ppm CO ₂ /°C
Other calculated humidity variables - dew point temperature, absolute humidity, specific humidity, mixing ratio, specific enthalpy	—	—	yes
Recommended calibration interval **	5 years	5 years	1 year
Protection class - case with electronics / CO ₂ probe / measuring end of stem	IP65 / IP65 / —	IP30 / — / —	IP30 / — / IP40
Temperature operating range of the case with electronics ***	-30 to +80 °C	-30 to +60 °C	-30 to +60 °C
Temperature operating range of the CO ₂ external probe	-25 to +60 °C	—	—
Temperature operating range of the measuring end of stem	—	—	-30 to +80 °C
Humidity operating range (no condensation)	0 to 100%RH	5 to 95%RH	5 to 95%RH
Atmospheric pressure operating range	850 to 1100 hPa	850 to 1100 hPa	850 to 1100 hPa
Mounting position	any position	cable glands upwards	sensor cover downwards
Storage temperature range (5 to 95%RH, no condensation, atmospheric pressure 700 to 1100 hPa)	-40 to +60 °C	-40 to +60 °C	-40 to +60 °C
Electromagnetic compatibility according to	EN 61326-1	EN 61326-1	EN 61326-1
Weight	420 (450, 510) g	330 g	350 g
Dimensions [mm]			

Electrical wiring

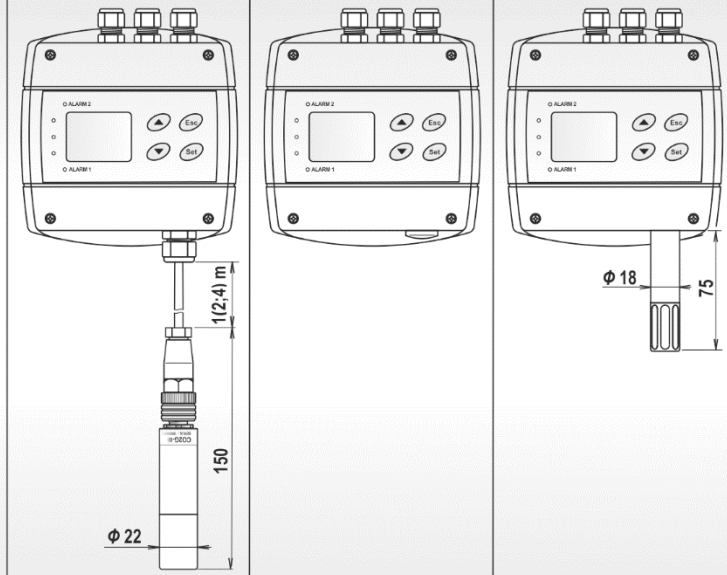
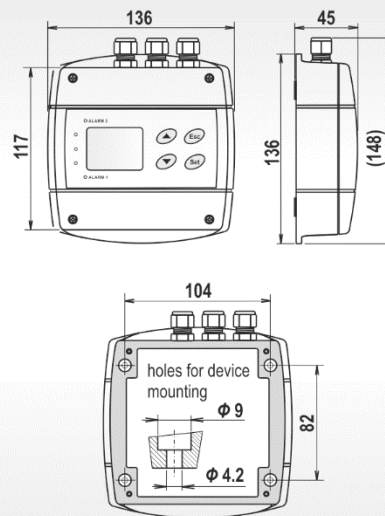
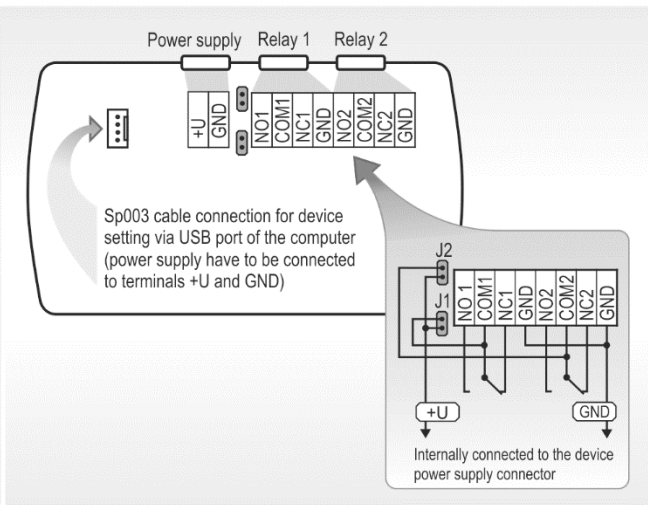

* LED indication (preset by manufacturer): **green** (0 to 1000 ppm), **yellow** (1000 to 1200 ppm), **red** (1200 to 2000/10000 ppm).

** Recommended calibration intervals: concentration CO₂ - 5 years, relative humidity - 1 year, temperature - 2 years

*** It is recommended to switch off the LCD display at ambient temperature above 70 °C